

**English:**

- Mount Lower Right Crash Bar according to the photo.

**Français:**

- Montez Crash Bar Inférieur Droit conformément à la photo.

**Português:**

- Montar Carenagem Inferior Direita conforme a foto.



**ALUMINUM TRAIL CRASH BAR**  
Ref.: 2AS197051A

20	Carenagem Inferior Esquerda / Lower Left Crash Bar	L51	1
19	Carenagem Superior Esquerda / Upper Left Crash Bar	L51	1
18	Carenagem Inferior Direita / Lower Right Crash Bar	R51	1
17	Carenagem Superior Direita / Upper Right Crash Bar	R51	1
16	Fixação Inox / Inox Clamp	Nº155A	2
15	Fixação Inox / Inox Clamp	Nº154A	1
14	Fixação Inox / Inox Clamp	Nº153	1
13	Casquilho Alumínio / Aluminum Bushing	∅20x∅11x25mm	1
12	Mola de Friso / Clip Inox	M6	1
11	Porca c. FA c. Bloqueio Metálico / Nut With Washer False Metal Lock	M8	2
10	Porca Freada / Nut Nylock	M6 - DIN 985	2
9	Anilha / Washer	M8 - DIN 125	2
8	Anilha / Washer	M6 - DIN 125	2
7	Paraf. Cabeça Cilíndrica Sext. Int. / Socket Head Cap Screw	M8x90 - DIN 912	1
6	Paraf. Cabeça Cilíndrica Sext. Int. / Socket Head Cap Screw	M8x70 - DIN 912	1
5	Paraf. Cabeça Cilíndrica Sext. Int. / Socket Head Cap Screw	M6x16 - DIN 912	4
4	Paraf. Cabeça Redonda Sext. Int. c. FA / Screw Round Head With Washer False	M8x45 - ISO 7380	1
3	Paraf. Cabeça Redonda Sext. Int. c. FA / Screw Round Head With Washer False	M8x20 - ISO 7380	2
2	Paraf. Cabeça Redonda Sext. Int. c. FA / Screw Round Head With Washer False	M6x25 - ISO 7380	6
1	Paraf. Cabeça Redonda Sext. Int. c. FA / Screw Round Head With Washer False	M6x16 - ISO 7380	2
<b>ITEM Nº:</b>	<b>COMPONENTE (COMPONENT):</b>	<b>DESCRIÇÃO (DESCRIPTION):</b>	<b>QUANT.:</b>
<b>ACESSÓRIOS (ACCESSORIES)</b>			





**English:**

- Remove plastics of origin in the area of the headlight.

**Français:**

- Retirer les plastiques d'origine dans la zone du phare.

**Português:**

- Remover plásticos de origem na zona do farol.

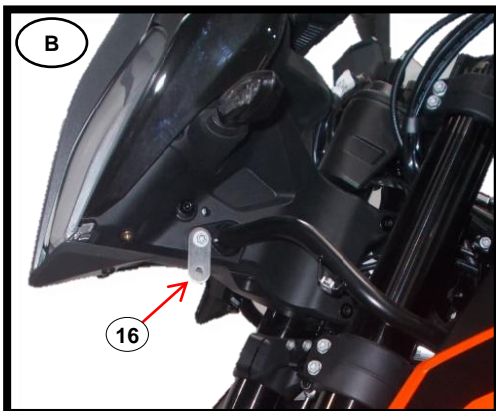

**English:**

- Remove original screw and apply item N°16 (Inox Clamp – x1) with original screw.

**Français:**

- Retirer vis d'origine et appliquer l'item N°16 (Fixation DTC – x1) avec le vis d'origine.

**Português:**

- Remover parafuso de origem e aplicar o item N°16 (Fixação Inox – x1) com o parafuso de origem.



**English:**

- Remove original screw marked in the photo. Repeat the process to the right side.

**Français:**

- Retirer vis d'origine marquée sur la photo. Répétez le processus du côté droit.

**Português:**

- Remover parafusos de origem marcado na foto. Repetir o processo para o lado direito.



**English:**

- Apply original plastic with original screws.

**Français:**

- Appliquer plastique d'origine avec les vis d'origine.

**Português:**

- Aplicar plástico de origem com os parafusos de origem.

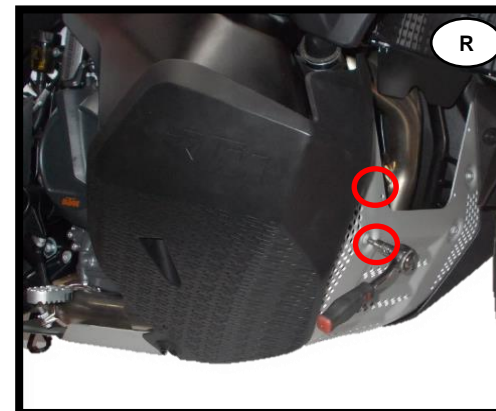

**English:**

- Remove original screws marked in the photo.

**Français:**

- Retirer vis d'origine marquée sur la photo.

**Português:**

- Remover parafusos de origem marcados na foto.

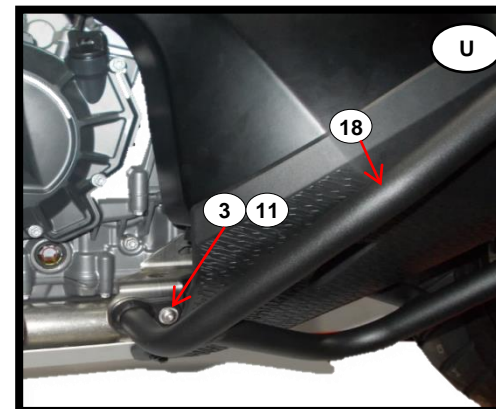

**English:**

- Mount Lower Right Crash Bar according to the photo.

**Français:**

- Montez Crash Bar Inférieur Droit conformément à la photo.

**Português:**

- Montar Carenagem Inferior Direita conforme a foto.

## ALUMINUM TRAIL CRASH BAR

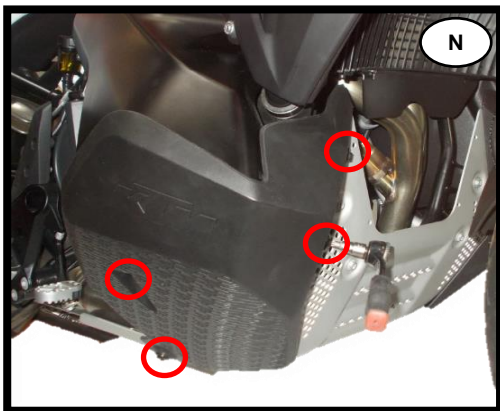

### English:

- Remove original screws marked in the photo and remove original plastic.

### Français:

- Retirer vis d'origine marquée sur la photo et retirer plastique d'origine.

### Português:

- Remover parafusos de origem marcados na foto e remover plástico de origem.

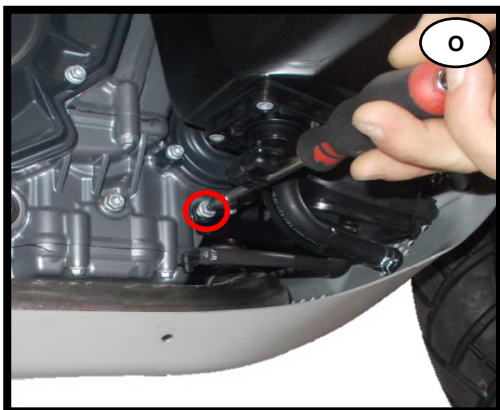

### English:

- Remove original screw marked in the photo.

### Français:

- Retirer vis d'origine marquée sur la photo.

### Português:

- Remover parafuso de origem marcado na foto.

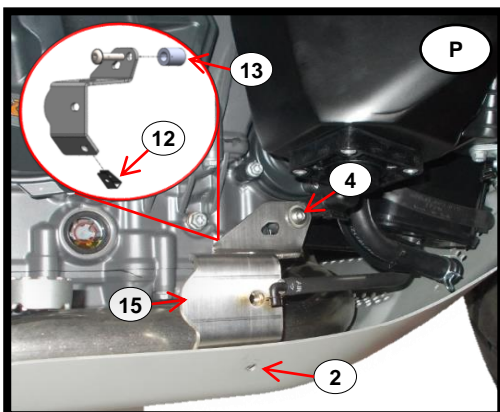

### English:

- Apply item N°15 (Inox Clamp – x1) with items N°4 (Screw – x1) and N°13 (Aluminum Bushing – x1).

### Français:

- Appliquer l'item N°15 (Fixation Inox – x1) avec les items N°4 (Vis – x1) et N°13 (Douille Aluminium – x1).

### Português:

- Aplicar item N°15 (Fixação Inox – x1) com os itens N°4 (Parafuso – x1) e N°13 (Casquilho Alumínio – x1).

## ALUMINUM TRAIL CRASH BAR

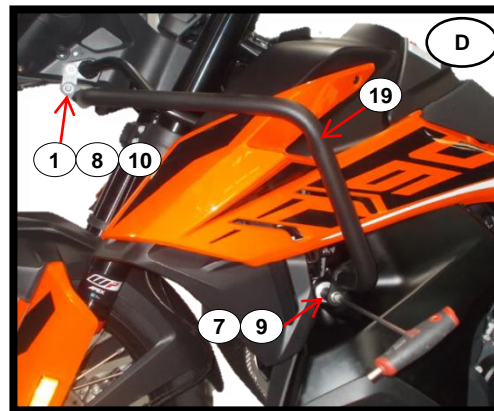

### English:

- Mount Upper Left Crash Bar according to the photo.

### Français:

- Montez Crash Bar supérieure Gauche conformément à la photo.

### Português:

- Montar Carenagem Superior Esquerda conforme a foto.



### English:

- Mount Upper Right Crash Bar according to the photo.

### Français:

- Montez Crash Bar supérieure Droit conformément à la photo.

### Português:

- Montar Carenagem Superior Direita conforme a foto.

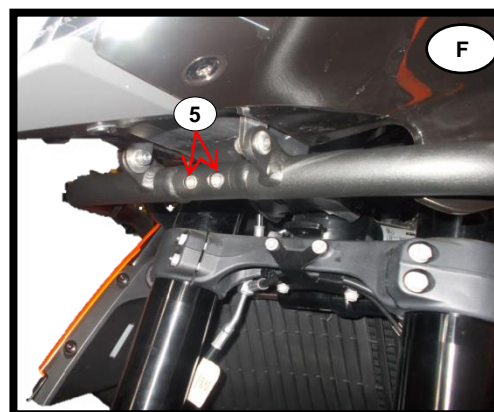

### English:

- Apply items according to the photo.

### Français:

- Appliquer les items conformément à la photo.

### Português:

- Aplicar os itens conforme a foto.

## ALUMINUM TRAIL CRASH BAR

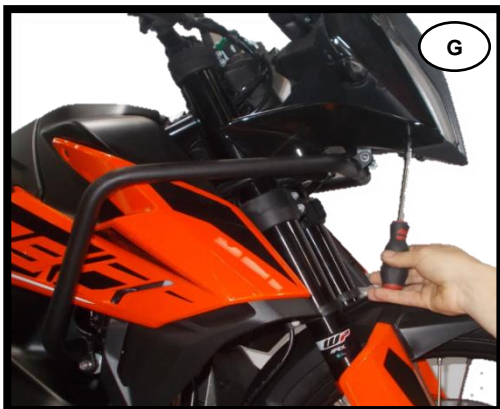

- English:**
- Apply plastic of origine.
- Français:**
- Appliquer le plastique d'origine.
- Português:**
- Aplicar plástico de origem.



- English:**
- Remove the two original screws marked in the photo.
- Français:**
- Retirer les deux vis d'origine marquée sur la photo.
- Português:**
- Remover os dois parafusos de origem marcados na foto.

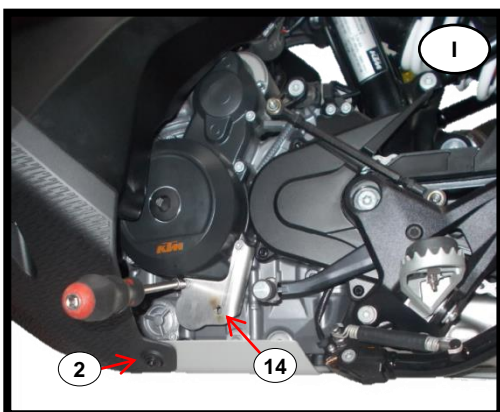

- English:**
- Apply item N°13 (Inox Clamp – x1) with original screws.
- Français:**
- Appliquer l'item N°13 (Fixation Inox – x1) avec les vis d'origine.
- Português:**
- Aplicar item N°13 (Fixação Inox – x1) com parafusos de origem.

## ALUMINUM TRAIL CRASH BAR



- English:**
- Remove original screws marked in the photo.
- Français:**
- Retirer vis d'origine marquée sur la photo.
- Português:**
- Remover parafusos de origem marcados na foto.

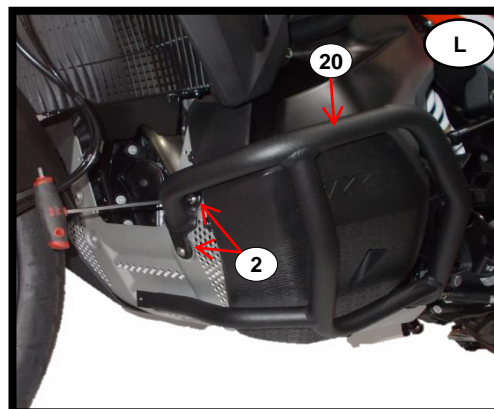

- English:**
- Mount Lower Left Crash Bar according to the photo.
- Français:**
- Montez Crash Bar Inférieur Gauche conformément à la photo.
- Português:**
- Montar Carenagem Inferior Esquerda conforme a foto.



- English:**
- Mount Lower Left Crash Bar according to the photo.
- Français:**
- Montez Crash Bar Inférieur Gauche conformément à la photo.
- Português:**
- Montar Carenagem Inferior Esquerda conforme a foto.