

English:

- Apply the rubbers removed in photo A with item N° 3 (Screw - x1).

► **ATTENTION:** do not tighten the screw.

Français:

- Appliquer les caoutchoucs retirés sur la photo A avec l'item N°3 (Vis - x1).

► **ATTENTION:** ne pas serrer la vis.

Português:

- Aplicar as borrachas removidas na photo A com o item N°3 (Parafuso - x1).

► **ATENÇÃO:** não dar aperto ao parafuso.

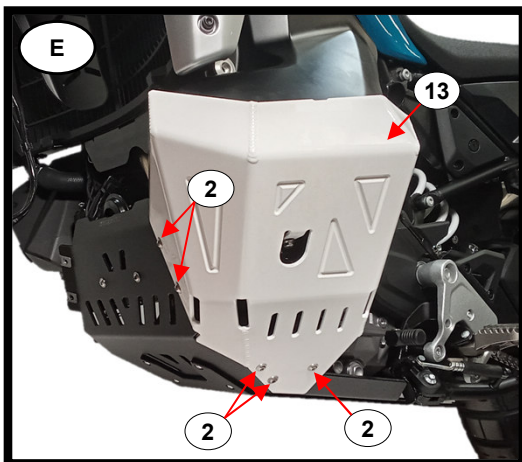

English:

- Mount the previous assembly on the motorcycle with item N°2 (Screw – x5).

Français:

- Montez l'ensemble précédent sur la moto avec l'item N°2 (Vis – x5).

Português:

- Montar assemblagem anterior com o item N°2 (Parafuso – x5).

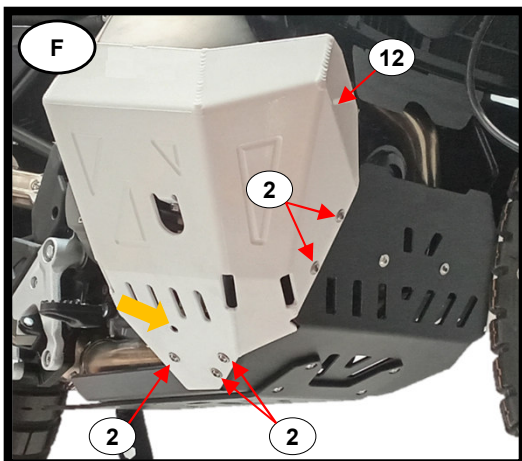

English:

- Repeat the previous process for the right side of the motorcycle with item N°12. Apply breather tube to the location marked in the photo. Torque all screws to the correct value.

Français:

- Répétez l'opération précédente pour le côté droit de la moto avec l'item N°12. Appliquez le tube de reniflard à l'emplacement indiqué sur la photo.

Torque toutes les vis avec le bonne valeur.

Português:

- Repetir o processo anterior para o lado direito da moto com o item N°12. Aplique o tubo de respiração no local assinalado na foto.

Apertar todos os parafusos com o valor correto de torque.

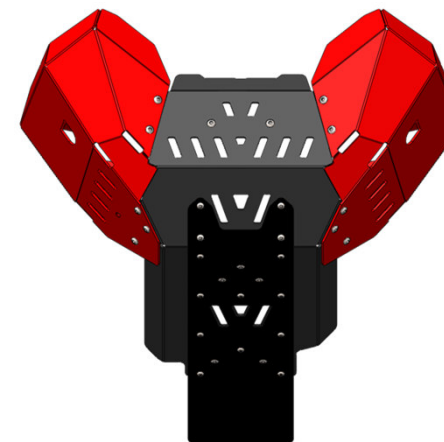

ALUMINUM TRAIL ENGINE GUARD

Ref.: 2AS0900119



Assembly Booklet / Paper collection
Livret de montage / Collecte de papier



Mini Zip Bag / Plastic collection
Mini sac zip / Collecte de plastique



Box / Paper collection
Boîte / Collecte de papier



Carton Separator / Paper collection
Séparateur de cartons / Collecte de papier



Card Header / Paper collection
Carte d'en-tête / Collecte de papier



Plastic Bag Cover / Plastic collection
Couverte de sac en plastique / Collecte de plastique



ASSEMBLY SEQUENCE / INSTRUÇÃO DE MONTAGEM

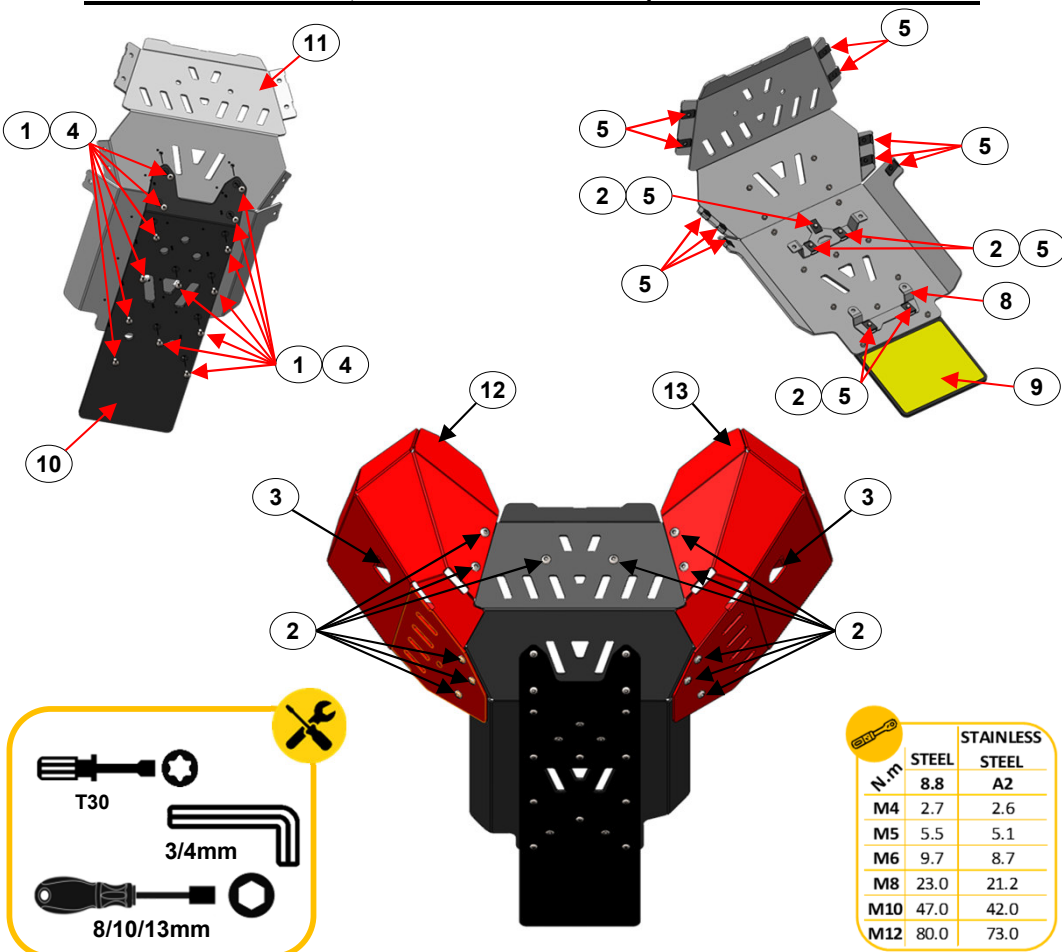

13	Proteção Motor / Engine Protection	L119	1
12	Proteção Motor / Engine Protection	R119	1
11	Proteção Motor (Central) / Engine Protection (Center)	119	1
10	Reforço DTC / DTC Reinforcement	Nº12	1
9	Tela Refletora Autocolante / Reflective Screen Sticker	Nº119	1
8	Fixação Inox / Stainless Steel Clamp	R119	1
7	Fixação Inox / Stainless Steel Clamp	F119	1
6	Tela Protetora / Protective Strip	700mm	1
5	Mola de Friso / Stainless Steel Clip	M6	15
4	Porca Freitada / Nut Nylock	M5 DIN985 A2	14
3	Parafuso / Screw	M6x16 DIN6921 A2	2
2	Parafuso com Falsa Anilha / Screw with Washer False	M6x16 FA ISO7380 A2	17
1	Parafuso com Falsa Anilha / Screw with Washer False	M5x12 FA ISO7380 A2	14
ITEM Nº:	COMPONENTE (COMPONENT):	DESCRIÇÃO (DESCRIPTION):	QUANT.:
ACESSÓRIOS (ACCESSORIES)			

ALUMINUM TRAIL ENGINE GUARD

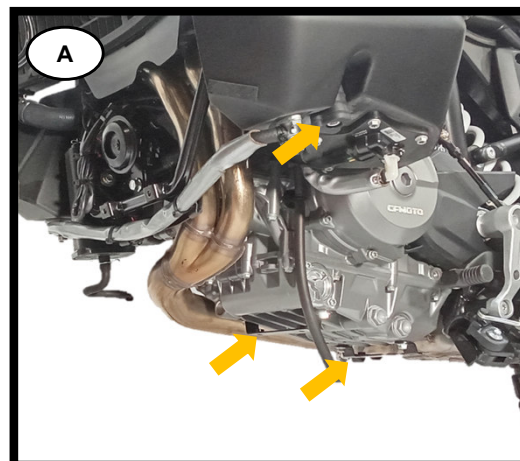

English:

- Remove OEM protection, clamps (x2) and rubbers (lefts and right sides) marked in the photo.

Français:

- Retirer la protection OEM, les fixations (x2) et caoutchoucs (côtés gauche et droit) marqués sur la photo.

Português:

- Remover a proteção OEM, as fixações (x2) e as borrachas (lados esquerdo e direito) assinaladas na foto.

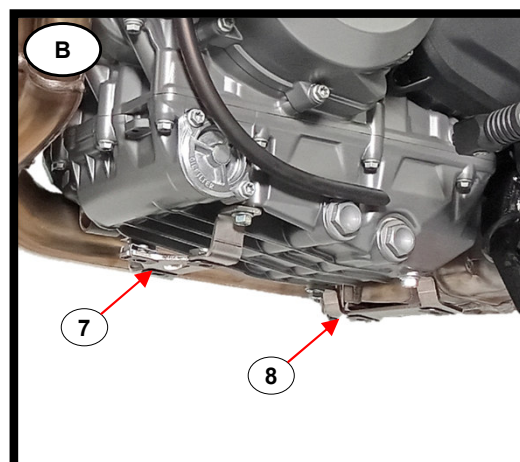

English:

- Apply items N°7 and N°8 (Stainless Steel Clamp – x2) with OEM screws (x4) according to the assembly instruction.

► **ATTENTION:** torque screws (x4) to the correct value.

Français:

- Appliquez les items N°7 et N°8 (Fixation Inox x2) avec les vis OEM (x4) conformément aux instructions de montage.

► **ATTENTION:** Torque les vis (x4) avec le bonne valeur.

Português:

- Aplicar os itens N°7 e N°8 (Fixação Inox – x2) com parafusos OEM (x4) de acordo com a instrução de montagem.

► **ATENÇÃO:** Apertar os parafusos (x4) com o valor correto de torque.

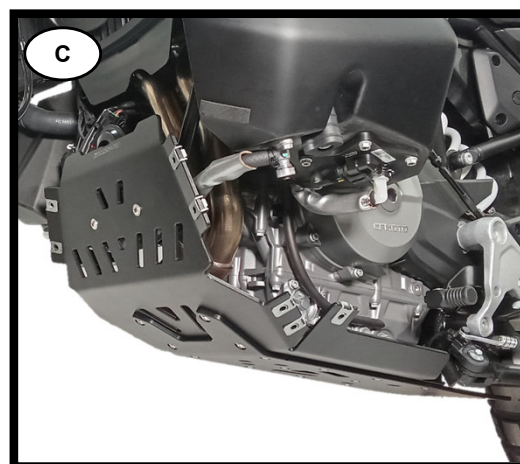

English:

- Apply item N°10 (DTC Reinforcement – x1) in item N°11 (Engine Protection – x1) and apply item N°9 (Reflective Screen Sticker – x1) according to the assembly instruction. Mount assemblage on the motorcycle with item N°2 (Screw – x7).

Français:

- Appliquer l'item N°10 (Renfort DTC – x1) sur l'item N°11 (Protection Moteur – x1) et appliquer l'item N°9 (Autocollant Réfléchissant – x1) conformément aux instructions de montage. Monter l'ensemble sur la moto à l'aide de l'item N°2 (Vis – x7).

Português:

- Aplicar o item N°10 (Reforço DTC – x1) no item N°11 (Proteção Motor – x1) e aplicar o item N°9 (Tela Refletora Autocolante – x1) de acordo com a instrução de montagem. Montar o conjunto na moto com o item N°2 (Parafuso – x7).