

**English:**

• Mount item N°6 (Inox Clamp – x1) according to the assembly instruction.

► **ATTENTION:** Add a little medium strength loctite and torque all screws to the correct value.

**Français:**

• Monter l'item N°6 (Fixation Inox – x1) selon les instructions de montage.

► **ATTENTION:** Ajouter un peu de loctite sur les vis et torque toutes les vis avec le bonne valeur.

**Português:**

• Montar o item N°6 (Fixação Inox – x1) de acordo com as instruções de montagem.

► **ATENÇÃO:** Adicionar um pouco de loctite nos parafusos e apertar todos os parafusos com o valor correto de torque.

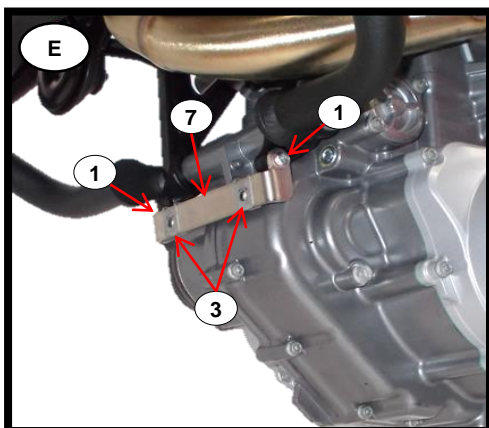

**English:**

• Mount item N°7 (Inox Clamp – x1) according to the assembly instruction.

► **ATTENTION:** Add a little medium strength loctite and torque all screws to the correct value.

**Français:**

• Monter l'item N°7 (Fixation Inox – x1) selon les instructions de montage.

► **ATTENTION:** Ajouter un peu de loctite sur les vis et torque toutes les vis avec le bonne valeur.

**Português:**

• Montar o item N°7 (Fixação Inox – x1) de acordo com as instruções de montagem.

► **ATENÇÃO:** Adicionar um pouco de loctite nos parafusos e apertar todos os parafusos com o valor correto de torque.

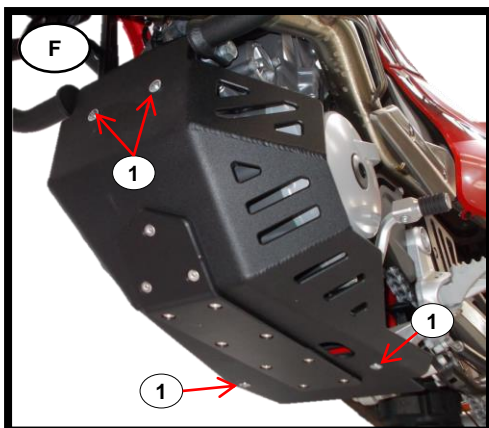

**English:**

• Mount Engine Guard with item N°1 (Screw – x4).

► **ATTENTION:** Add a little medium strength loctite and torque all screws to the correct value.

**Français:**

• Monter la protection avec l'item N°1 (Vis – x4).

► **ATTENTION:** Ajouter un peu de loctite sur les vis et torque toutes les vis avec le bonne valeur.

**Português:**

• Montar a proteção com o item N°1 (Parafuso – x4).

► **ATENÇÃO:** Adicionar um pouco de loctite nos parafusos e apertar todos os parafusos com o valor correto de torque.

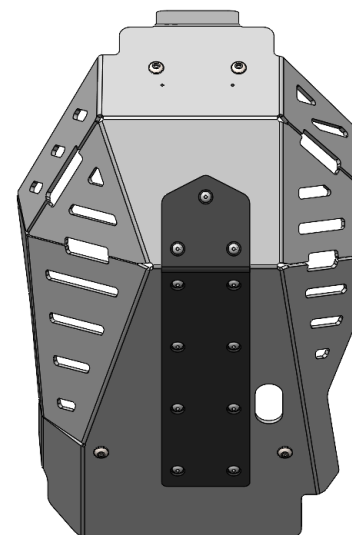

## ALUMINUM TRAIL ENGINE GUARD

Ref.: 2AS0900089

# ASSEMBLY INSTRUCTION / INSTRUÇÃO DE MONTAGEM

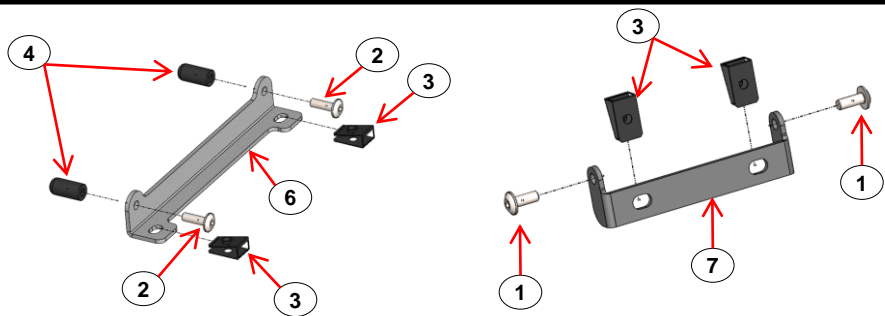

N.m (TORQUE)		
	AÇO / STEEL	INOX
M4	2,7	0,8
M5	5,5	1,7
M6	9,7	3
M8	23	7,9
M10	47	14

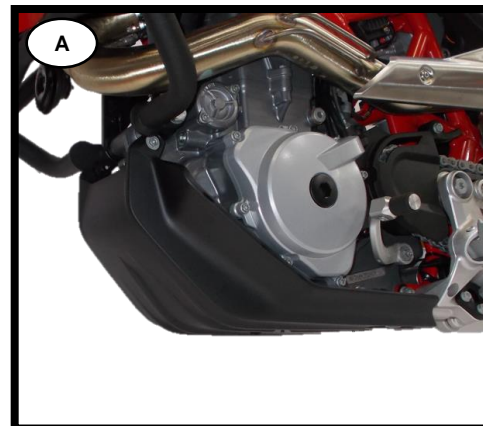
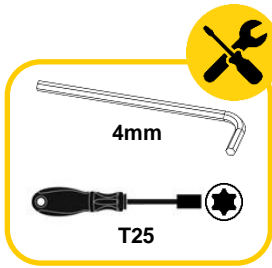
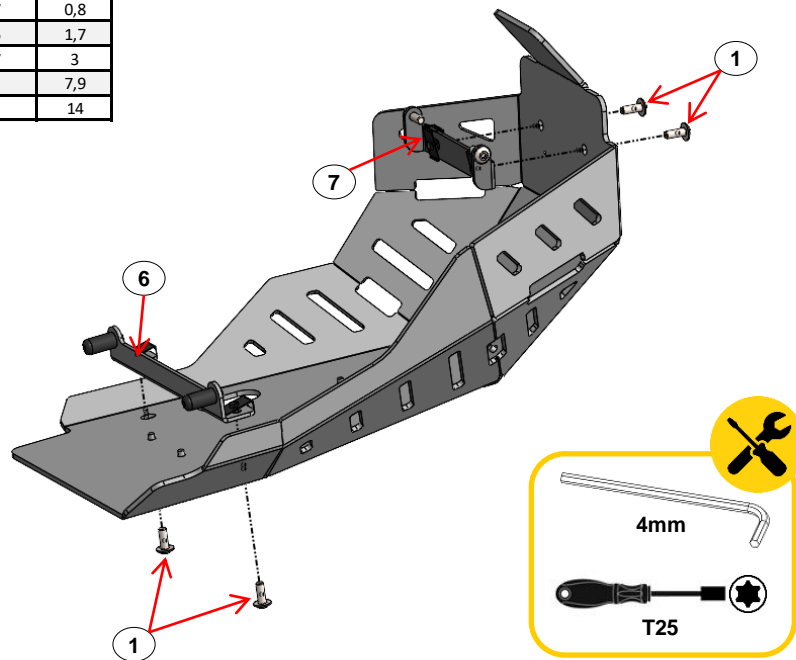

- English:**
- Remove OEM protection.
- Français:**
- Retirer la protection OEM.
- Português:**
- Remover proteção OEM.

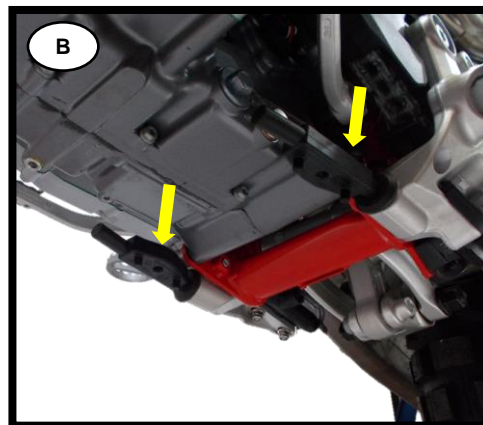

- English:**
- Remove OEM clamps.
- Français:**
- Retirer les fixations OEM.
- Português:**
- Remover fixações OEM.

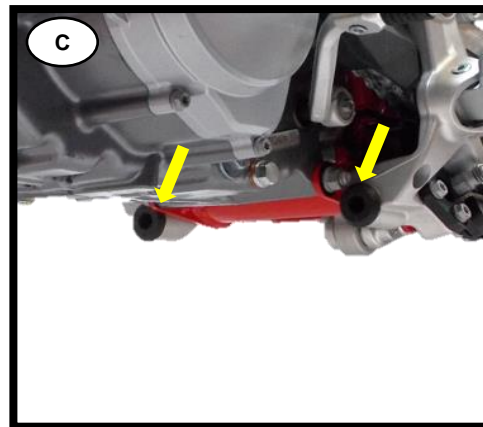

- English:**
- Keep OEM rubber bushings.
- Français:**
- Conservez douille en caoutchouc OEM.
- Português:**
- Manter casquilhos OEM de borracha.



6	Fixação Inox / Inox Clamp	B89	1
5	Fixação Inox / Inox Clamp	A89	1
4	Casquilho Alumínio / Aluminum Bushing	Ø12xM6x25mm	2
3	Mola de Friso / Inox Clip	M6	4
2	Paraf. Cabeça Redonda Sext. Int. c. FA / Round Head Screw With Washer False	M6x20 - ISO 7380	2
1	Paraf. Cabeça Redonda Sext. Int. c. FA / Round Head Screw With Washer False	M6x16 - ISO 7380	6
<b>ITEM Nº: COMPONENTE (COMPONENT):</b>		<b>DESCRIÇÃO (DESCRIPTION):</b>	<b>QUANT.:</b>
ACESSÓRIOS (ACCESSORIES)			