

ALUMINUM TRAIL ENGINE GUARD

Ref.: 2AS0900075

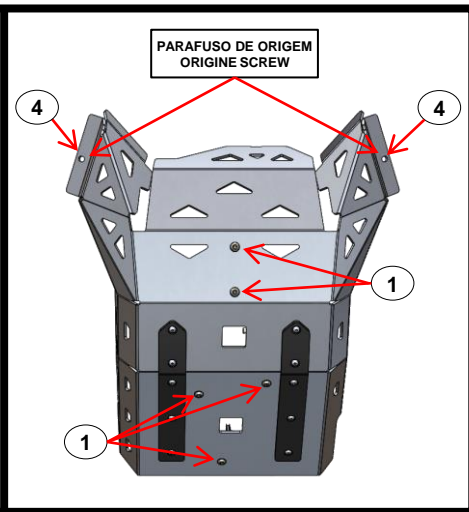

ASSEMBLY INSTRUCTION / INSTRUÇÃO DE MONTAGEM

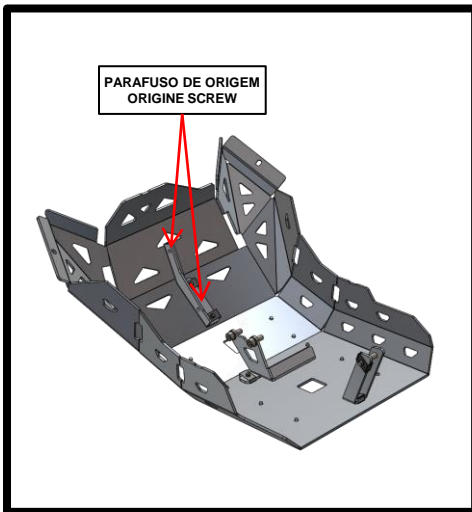
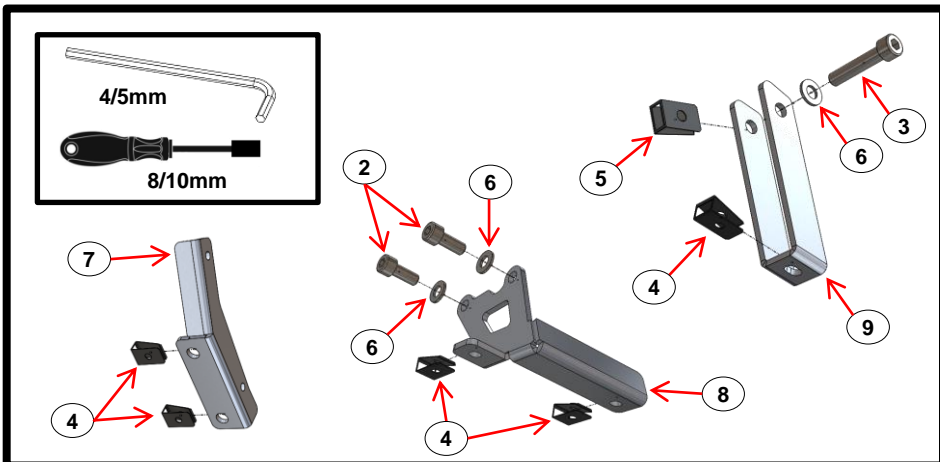

9	Fixação Inox / Inox Clamp	C75	1
8	Fixação Inox / Inox Clamp	B75	1
7	Fixação Inox / Inox Clamp	A75	1
6	Anilha / Washer	M8 - DIN 125	3
5	Mola de Friso / Clip Inox	M8	1
4	Mola de Friso / Clip Inox	M6	7
3	Paraf. Cabeça Cilíndrica Sext. Int. / Socket Head Cap Screw	M8x40 - DIN 912	1
2	Paraf. Cabeça Cilíndrica Sext. Int. / Socket Head Cap Screw	M8x20 - DIN 912	2
1	Paraf. Cabeça Redonda Sext. Int. c. FA / Screw Round Head With Washer False	M6x16 - ISO 7380	5
ITEM Nº: COMPONENTE (COMPONENT):		DESCRIÇÃO (DESCRIPTION):	QUANT.:
ACESSÓRIOS (ACCESSORIES)			



English:

- Apply origine screw as indicated in the photo - do not tighten.

Français:

- Appliquer le vis d'origine comme indiqué sur la photo - ne serrez pas.

Português:

- Aplicar parafuso de origem como indicado na foto – não dar aperto.

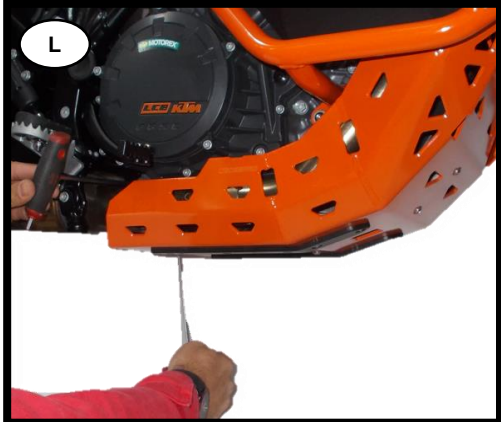

English:

- Apply item N°1 (Screw – x1) in the rear part of the protection in the item N°9 (Inox Clamp) previously mounted - do not tighten.

Français:

- Appliquer l'item N°1 (Vis – x1) sur la partie arrière de la protection dans l'item N°9 (Fixation Inox) précédemment monte - ne serrez pas.

Português:

- Aplicar o item N°1 (Parafuso – x1) na parte de trás da proteção no item N°9 (Fixação Inox) montada anteriormente – não dar aperto.

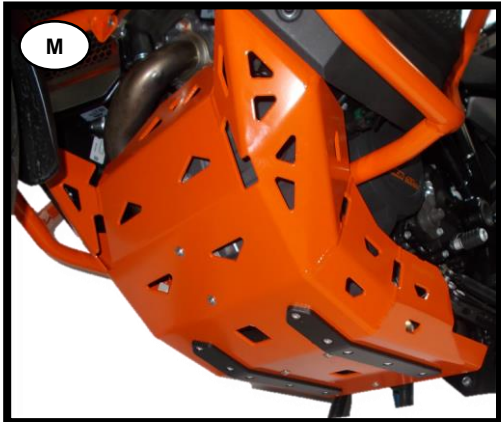

English:

- Tighten all screws starting from the front part.

Français:

- Serrer toutes les vis en commençant par la partie avant.

Português:

- Apertar todos os parafusos iniciando pela parte da frente.



English:

- Remove origine protection.

Français:

- Retirer la protection d'origine.

Português:

- Remover proteção de origem.

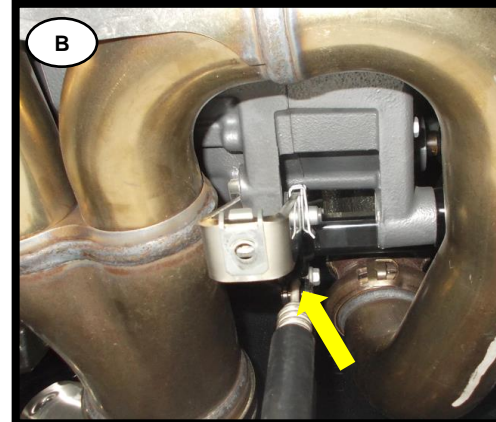

English:

- Apply items N°4 (Clip Inox – x1) and N°5 (Clip Inox – x1) on the item N°9 (Inox Clamp – x1) and mount assembly on the motorcycle with items N°3 (Screw – x1) and N°6 (Washer – x1) – see instruction page 2.

Français:

- Appliquer les items N°4 (Clip Inox – x1) et N°5 (Clip Inox – x1) sur l'item N°9 (Fixation Inox – x1) et monter assemblage sur la moto avec les items N°3 (Vis – x1) et N°6 (Rondelle – x1) – voir schéma page 2.

Português:

- Aplicar os itens N°3 (Mola de Friso – x1) e N°5 (Mola de Friso – x1) no item N°9 (Fixação Inox – x1) e montar assemblagem na moto com os itens N°3 (Parafuso – x1) e N°6 (Anilha – x1) – ver esquema página 2.

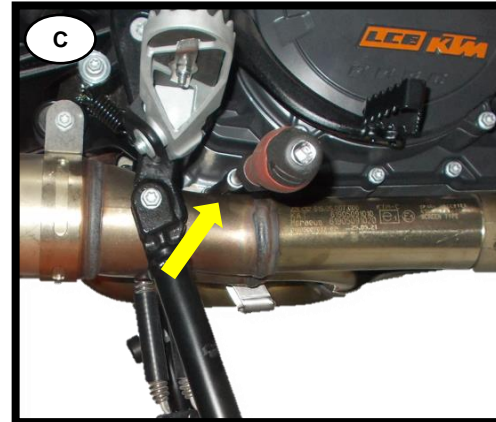

English:

- Adjust the screw - do not tighten.

Français:

- Régler le vis - ne serrez pas.

Português:

- Ajustar o parafuso – não dar aperto.

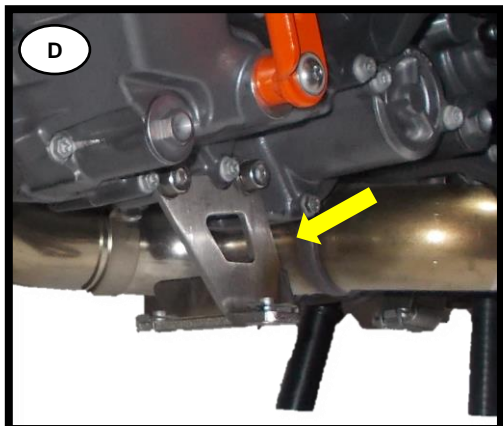

English:

- Apply item N°4 (Clip Inox – x2) on the item N°8 (Inox Clamp – x1) and mount assembly on the motorcycle with items N°2 (Screw – x2) and N°6 (Washer – x2) – Tighten the Inox Clamp screws. (see instruction page 2)

Français:

- Appliquer l'item N°4 (Clip Inox – x2) sur l'item N°8 (Fixation Inox – x1) et monter assemblage sur la moto avec les items N°2 (Vis – x2) et N°6 (Rondelle – x2) – Serrer les vis de Fixation Inox. (voir schéma page 2)

Português:

- Aplicar o item N°4 (Mola de Friso – x2) no item N°8 (Fixação Inox – x1) e montar assemblagem na moto com os itens N°2 (Parafuso – x2) e N°6 (Anilha – x2) – Dar aperto aos parafusos da Fixação Inox. (ver esquema página 2)

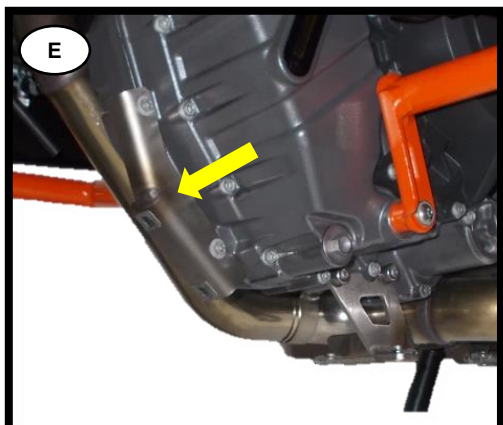

English:

- Apply item N°4 (Clip Inox – x2) on the item N°7 (Inox Clamp – x1) and mount assembly on the motorcycle with origine screw – Tighten the Inox Clamp screws. (see instruction page 2)

Français:

- Appliquer l'item N°4 (Clip Inox – x2) sur l'item N°7 (Fixation Inox – x1) et monter assemblage sur la moto avec les vis d'origine – Serrer les vis de Fixation Inox. (voir schéma page 2)

Português:

- Aplicar o item N°4 (Mola de Friso – x2) no item N°7 (Fixação Inox – x1) e montar assemblagem na moto com parafusos de origem – Dar aperto aos parafusos da Fixação Inox. (ver esquema página 2)



English:

- Apply item N°4 (Clip Inox – x2) on the protection and mount protection on the motorcycle – attention to the front plastics. (see instruction page 2)

Français:

- Appliquer l'item N°4 (Clip Inox – x2) sur la protection and monter la protection sur la moto – attention aux plastiques avant. (voir schéma page 2)

Português:

- Aplicar o item N°4 (Mola de Friso – x2) na proteção e montar proteção na moto – atenção aos plásticos da frente. (ver esquema página 2)



English:

- Apply item N°1 (Screw – x2) in the middle part of the protection in the item N°8 (Inox Clamp) previously mounted - do not tighten.

Français:

- Appliquer l'item N°1 (Vis – x2) sur la partie médiane de la protection dans l'item N°8 (Fixation Inox) précédemment monte - ne serrez pas.

Português:

- Aplicar o item N°1 (Parafuso – x2) na parte do meio da proteção no item N°8 (Fixação Inox) montada anteriormente – não dar aperto.



English:

- Apply item N°1 (Screw – x2) in the front part of the protection in the item N°7 (Inox Clamp) previously mounted - do not tighten.

Français:

- Appliquer l'item N°1 (Vis – x2) sur la partie avant de la protection dans l'item N°7 (Fixation Inox) précédemment monte - ne serrez pas.

Português:

- Aplicar o item N°1 (Parafuso – x2) na parte da frente da proteção no item N°7 (Fixação Inox) montada anteriormente – não dar aperto.



English:

- Apply origine screw as indicated in the photo - do not tighten.

Français:

- Appliquer le vis d'origine comme indiqué sur la photo - ne serrez pas.

Português:

- Aplicar parafuso de origem como indicado na foto – não dar aperto.